

VIEW A-A
SCALED: NONE

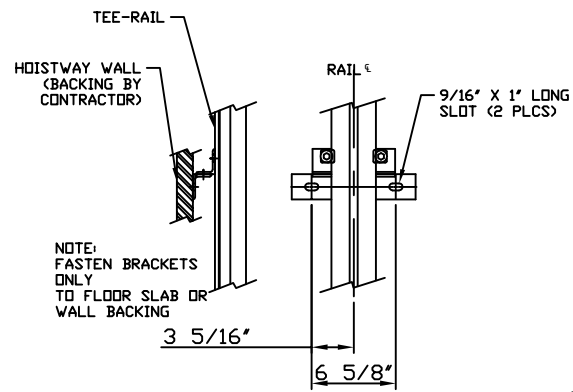

MAX VERTICAL BRACKET SPACING IS 12'-0"
DETAIL B
RAIL BRACKET ASSEMBLY

MATOT EQUIPMENT IS MANUFACTURED TO THE LATEST EDITION OF ANSI A17.1/CSA B44 OR B20 CODE. IT IS THE RESPONSIBILITY OF THE PURCHASER TO CONFIRM COMPLIANCE WITH ANY LOCAL STATE OR CITY CODES.

TYPICAL
THESE DRAWINGS ARE TYPICAL AND REPRESENT STANDARD EQUIPMENT AND APPLICATIONS IF YOU HAVE A NEED BEYOND THE SCOPE OF THESE TYPICAL DRAWINGS MATOT CAN PROVIDE A SOLUTION. PLEASE CALL MATOT AT (800) 369-1070

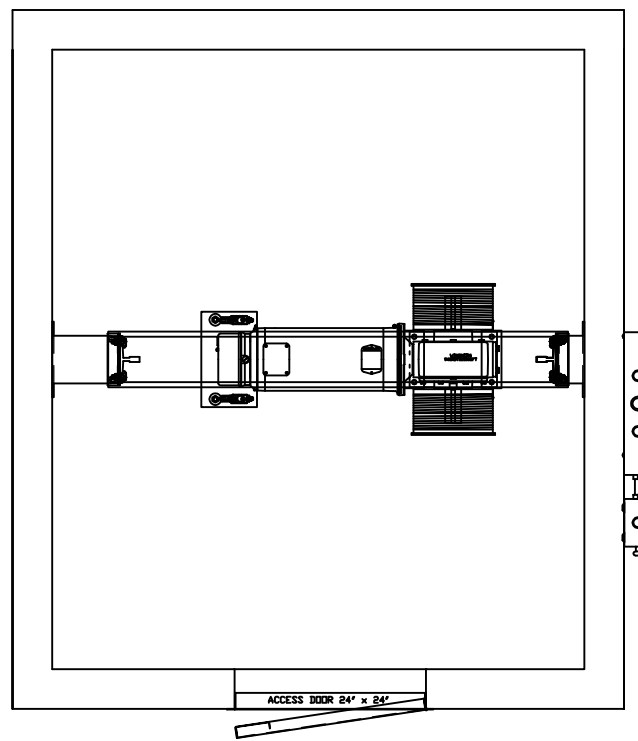

MACHINE PLAN
SCALED: NONE

HOISTWAY DIMENSIONS WILL CHANGE PROPORTIONALLY TO CAR SIZE CHANGES

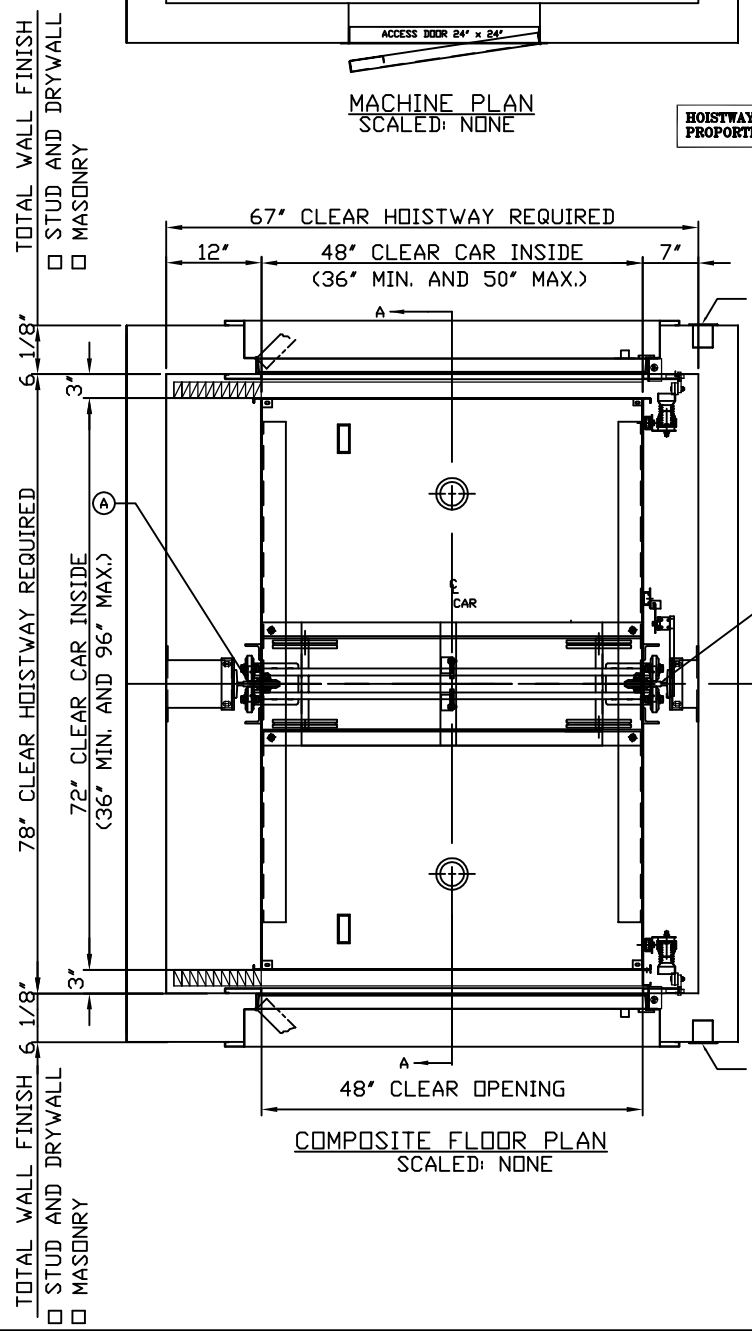

TOTAL WALL FINISH
 STUD AND DRYWALL
 MASONRY

IMPORTANT:
BEFORE APPROVING THIS LAYOUT NOTE THAT THE FOLLOWING MUST BE PROVIDED BUT ARE NOT INCLUDED IN VRC CONTRACT:

- GENERAL NOTES**
- Power feed with line disconnect switch must be brought to immediate vicinity of our controller.
 - Hoistway free of all pipes and obstructions.
 - All bracket fastening inserts and steel required for support of guide rail and brackets, to be furnished by others.
 - Self-supporting tower units to be installed before hatch walls are erected.
 - All truckable units require 2 inch deep pockets for trucking sills.

WEIGHT OF MACHINE (EST.)	400 LBS.
WEIGHT OF CAR (EST.)	2830
REACTIONS	
A	2440 LBS. (STATIC)
B	100 LBS. (LATERAL)
C	
OPENINGS	-- LOCATED OPPOSITE SIDES OF HOISTWAY
STOPS	: 2 MINIMUM AND 5 MAXIMUM, MORE STOPS CAN BE PROVIDED BUT SPECIAL ENGINEERING IS REQ. CALL MATOT (800) 369-1070
MISC.	PREWIRED CAR TOP WITH ATTACHED TRAVEL CABLE RETIRING CAM W/ DOUBLE CONTACT INTERLOCK

CAR MATL.	<input checked="" type="checkbox"/> STAINLESS STEEL OR CARBON STEEL
	FINISH: NO. 4 DR AIR DRIED GREY ENAMEL
CABLE SIZE	<input checked="" type="checkbox"/> 3/16 x 7 x 19 2-REQD.
	<input checked="" type="checkbox"/> BREAKING STRENGTH 4200 LBS. EACH CABLE
CAR GATES	<input checked="" type="checkbox"/> COLLAPSIBLE
DOORS	<input checked="" type="checkbox"/> SWING DOORS BY OTHERS
	<input checked="" type="checkbox"/> GAL INTERLOCKS BY MATOT
SILLS	<input checked="" type="checkbox"/> TRUCKABLE STAINLESS STEEL OR CARBON STEEL
ACCESS & CLEAN-OUT DOOR	<input checked="" type="checkbox"/> STAINLESS STEEL OR CARBON STEEL
	FINISH: NO. 4 DR AIR DRIED GREY ENAMEL
HOISTWAY EQUIP.	<input checked="" type="checkbox"/> B# TEE RAIL

CAR SAFETY:	BROKEN CABLE DEVICE
CWT. SAFETY:	NONE
BUFFERS:	NONE
MACHINE DESIGN	<input checked="" type="checkbox"/> DRUM OVERHEAD
	<input checked="" type="checkbox"/> DRUM #PD1052RP/PD1052LP REDUCER 943MDT 60:1
H.P.	VOLTS 208-230 DR 460-480 PH. CYL. 40 AMPS.
OPERATION:	SINGLE AUTOMATIC CALL AND SEND STARTING: RUNNING:
CONTROL	<input checked="" type="checkbox"/> V.V.V.F.
	<input checked="" type="checkbox"/> IN USE LIGHT
SIGNALS	<input checked="" type="checkbox"/> CAR HERE LIGHT AND CHIME
	<input checked="" type="checkbox"/> DOOR OPEN BUZZER

CAPACITY:	1200 LBS.	F.P.M. 40	TRAVEL:
TYPE VRC:	ELEC. MODEL # 840A		
PROJECT:			
ARCHITECT:			
GENERAL CONTRACTOR:			
CONTRACT WITH:			
REVISIONS	DATE		DATE

Matot, Inc.

SPECIALIZING IN SINCE 1888
DUMBWAITERS, BOOKLIFTS, RECORD CARRIERS, D. W. DOORS
2501 VAN BUREN, BELLWOOD, ILLINOIS 60104
PHONE: AREA CODE (708) 547-1888

PRELIM. PRINT	FINAL	DRAWN BY	CHECKED
JOB No.	SHEET 1 OF 1	DRAWING No.	OPPOSITE FLOOR COLLAPSIBLE 48" X 72" X 78"