

VIEW A-A, ELEVATION
SCALED: NONE

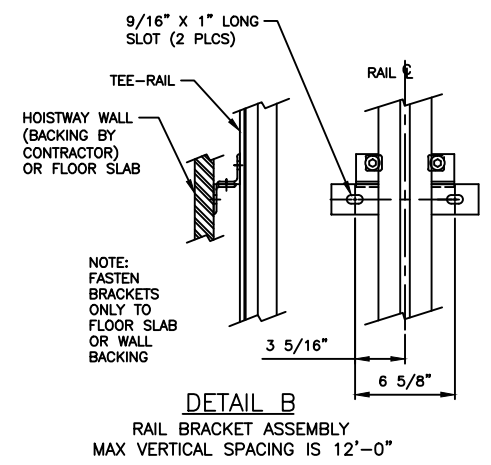

IF WALLS CANNOT SUPPORT MAXIMUM LATERAL REACTIONS OF RAIL BRACKETS A SELF SUPPORTING TOWER CAN BE PROVIDED INSIDE THE HOISTWAY THAT ONLY REQUIRES SUPPORT AT THE FLOOR, INTERMEDIATE FLOOR SLABS, AND AT THE TOP OF RAIL

MATOT EQUIPMENT IS MANUFACTURED TO THE LATEST EDITION OF ANSI A17.1/CSA B44 CODE. IT IS THE RESPONSIBILITY OF THE PURCHASER TO CONFIRM COMPLIANCE WITH ANY LOCAL STATE OR CITY CODES.

TYPICAL
THESE DRAWINGS ARE TYPICAL AND REPRESENT STANDARD EQUIPMENT AND APPLICATIONS IF YOU HAVE A NEED BEYOND THE SCOPE OF THESE TYPICAL DRAWINGS MATOT CAN PROVIDE A SOLUTION. PLEASE CALL MATOT AT (800) 369-1070

****CAR MAXIMUM PLATFORM AREA (WIDTH X DEPTH) CANNOT EXCEED 1,548 IN. SQ. BY ANSI 17.1 CODE**

MINIMUM WALL THICKNESS REQUIRED FOR U.L. LABEL DOOR IS 3 1/2" MAXIMUM WALL THICKNESS IS 13 1/2"

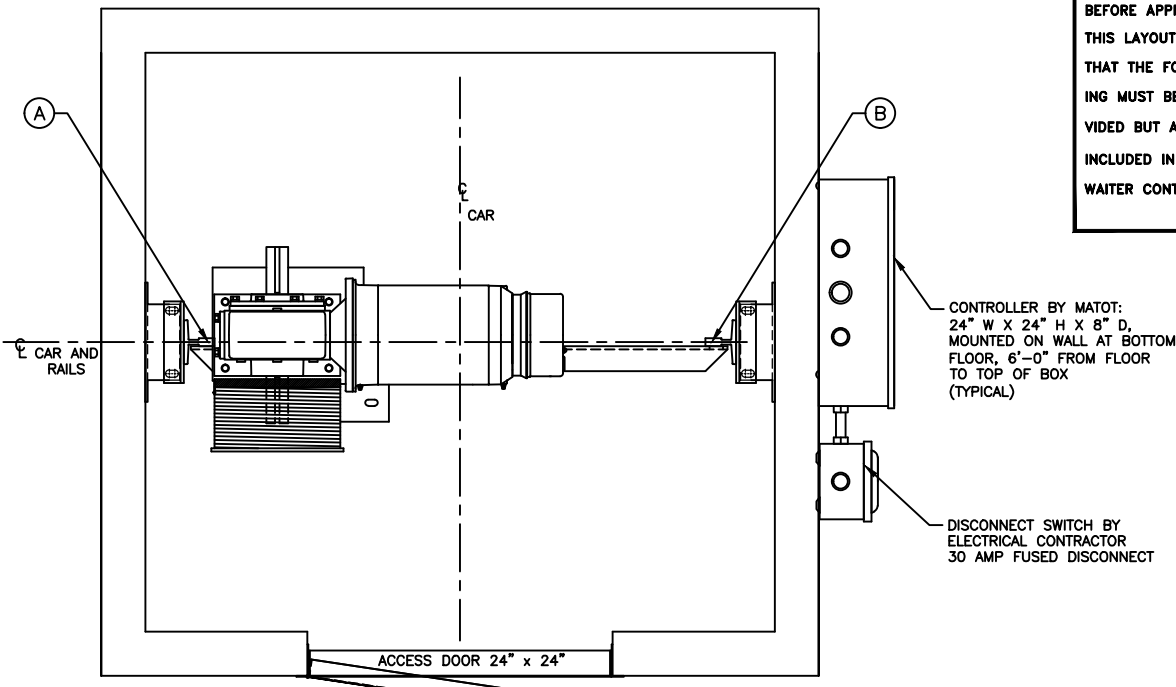

MACHINE PLAN
SCALED: NONE

HOISTWAY DIMENSIONS WILL CHANGE PROPORTIONALLY TO CAR SIZE CHANGES

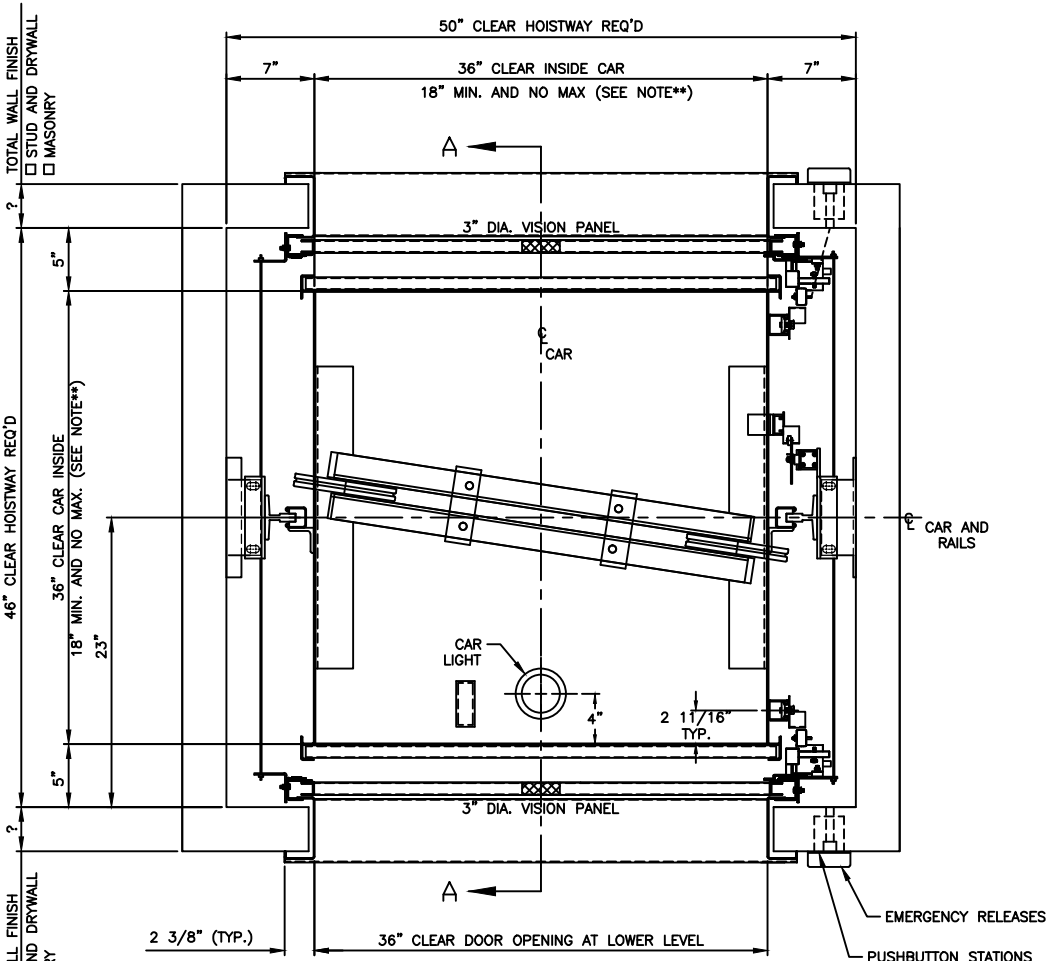

COMPOSITE FLOOR PLAN
SCALED: NONE

IMPORTANT:
BEFORE APPROVING THIS LAYOUT NOTE THAT THE FOLLOWING MUST BE PROVIDED BUT ARE NOT INCLUDED IN DUMBWAITER CONTRACT:

GENERAL NOTES
a. Power feed with line disconnect switch must be brought to immediate vicinity of our controller.
b. Hoistway free of all pipes and obstructions.
c. All bracket fastening inserts and steel required for support of guide rail and brackets, to be furnished by others.

WEIGHT OF MACHINE (EST.)	195 LBS.
WEIGHT OF CAR (EST.)	1090 LBS. (GROSS)
REACTIONS	
A	1710 LBS. ESTIMATE (STATIC, AT PIT FLOOR)
B	1170 LBS. ESTIMATE (STATIC, AT PIT FLOOR)
C	50 LBS. (LATERAL, MAX. AT WALL BRACKET)
OPENINGS	LOCATED OPPOSITE SIDES OF HOISTWAY
STOPS	2 MINIMUM TO 5 MAXIMUM, MORE STOPS CAN BE PROVIDED HOWEVER SPECIAL ENGINEERING IS REQUIRED CALL MATOT (800) 369-1070
MISC:	PREWIRED CAR TOP & ATTACHED TRAVEL CABLE
SHELF	<input checked="" type="checkbox"/> REMOVABLE 1-REQD.
CAR MATL.	<input checked="" type="checkbox"/> STAINLESS STEEL OR CARBON STEEL FINISH: NO. 4 OR AIR DRIED GREY ENAMEL
CABLE SIZE	<input checked="" type="checkbox"/> 3/16 x 7 x 19 1-REQD. <input checked="" type="checkbox"/> BREAKING STRENGTH 4200 LBS. EACH CABLE
CAR GATES	<input checked="" type="checkbox"/> STAINLESS STEEL OR CARBON STEEL <input checked="" type="checkbox"/> BI-PARTING <input checked="" type="checkbox"/> MANUAL OR POWER (PLEASE SEE OVERHEAD REQUIREMENTS)
DOORS	<input checked="" type="checkbox"/> FINISH: NO. 4 OR AIR DRIED GREY ENAMEL <input checked="" type="checkbox"/> U/L B LABEL <input checked="" type="checkbox"/> STAINLESS STEEL OR CARBON STEEL <input checked="" type="checkbox"/> BI-PARTING <input checked="" type="checkbox"/> MANUAL OR POWER (PLEASE SEE OVERHEAD REQUIREMENTS) FINISH: NO. 4 OR AIR DRIED GREY ENAMEL
SILLS	<input checked="" type="checkbox"/> COUNTER HEIGHT, STAINLESS STEEL OR CARBON STEEL
ACCESS & CLEAN-OUT DOOR	<input checked="" type="checkbox"/> STAINLESS STEEL OR CARBON STEEL <input checked="" type="checkbox"/> U/L B LABEL
HOISTWAY EQUIP.	<input checked="" type="checkbox"/> FINISH: NO. 4 OR AIR DRIED GREY ENAMEL <input checked="" type="checkbox"/> 8# TEE RAIL
CAR SAFETY:	BROKEN CABLE DEVICE
CWT. SAFETY:	NONE
BUFFERS:	NONE
MACHINE DESIGN	<input checked="" type="checkbox"/> DRUM BELOW <input checked="" type="checkbox"/> DRUM <input checked="" type="checkbox"/> REDUCER - 935MDT, 182TC FACE, 50:1 RATIO

H.P.3	VOLTS 208-230 OR 460-480 PH. 3	CYL. 60	AMPS.
OPERATION:	SINGLE AUTOMATIC CALL AND SEND		STARTING: RUNNING:
CONTROL	<input checked="" type="checkbox"/> SINGLE SPEED <input checked="" type="checkbox"/> IN USE LIGHT		
SIGNALS	<input checked="" type="checkbox"/> CAR HERE LIGHT AND CHIME <input checked="" type="checkbox"/> DOOR OPEN BUZZER		

CAPACITY:	500 LBS.	F.P.M.50	TRAVEL:
TYPE DUMBWAITER:	ELEC.	MODEL #100	
PROJECT:			
ARCHITECT:			
GENERAL CONTRACTOR:			
CONTRACT WITH:			
REVISIONS	DATE	DATE	DATE

MATOT, INC.

SPECIALIZING IN DUMBWAITERS, BOOKLIFTS, RECORD CARRIERS, D. W. DOORS SINCE 1888

2501 VAN BUREN, BELLWOOD, ILLINOIS 60104

PHONE: AREA CODE (708) 547-1888

PRELIM. PRINT	FINAL	DRAWN BY	CHECKED
JOB No.	1	SHEET OF 1	DRAWING No. OPPOSITE COUNTER BP 36W X 36D X 48H