

VIEW A-A ELEVATION
SCALED: NONE

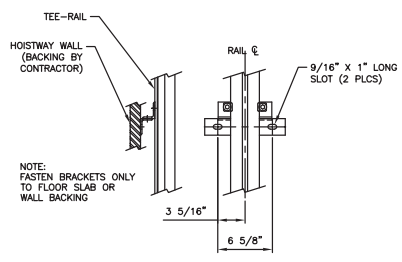

DETAIL B
RAIL BRACKET ASSEMBLY

IF WALLS CANNOT SUPPORT MAXIMUM LATERAL REACTIONS OF RAIL BRACKETS A SELF SUPPORTING TOWER CAN BE PROVIDED INSIDE THE HOISTWAY THAT ONLY REQUIRES SUPPORT AT THE FLOOR, INTERMEDIATE FLOOR SLABS, AND AT THE TOP OF RAIL.

MATOT EQUIPMENT IS MANUFACTURED TO THE LATEST EDITION OF ANSI 17.1/CSA B44 CODE. IT IS THE RESPONSIBILITY OF THE PURCHASER TO CONFIRM COMPLIANCE WITH ANY LOCAL STATE OR CITY CODES.

TYPICAL
THESE DRAWINGS ARE TYPICAL AND REPRESENT STANDARD EQUIPMENT AND APPLICATIONS IF YOU HAVE A NEED BEYOND THE SCOPE OF THESE TYPICAL DRAWINGS MATOT CAN PROVIDE A SOLUTION. PLEASE CALL MATOT AT (800) 369-1070

**CAR MAXIMUM PLATFORM AREA (WIDTH X DEPTH) CANNOT EXCEED 1,548 IN. SQ. BY ANSI 17.1 CODE

MINIMUM WALL THICKNESS REQUIRED FOR U.L. LABEL DOOR IS 3 1/2\"/>

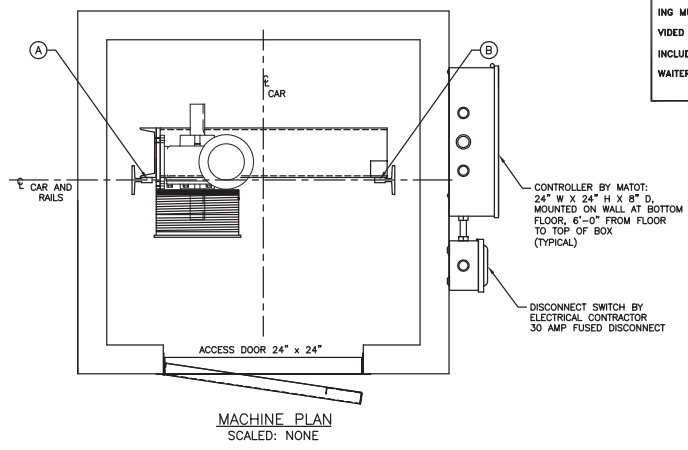

MACHINE PLAN
SCALED: NONE

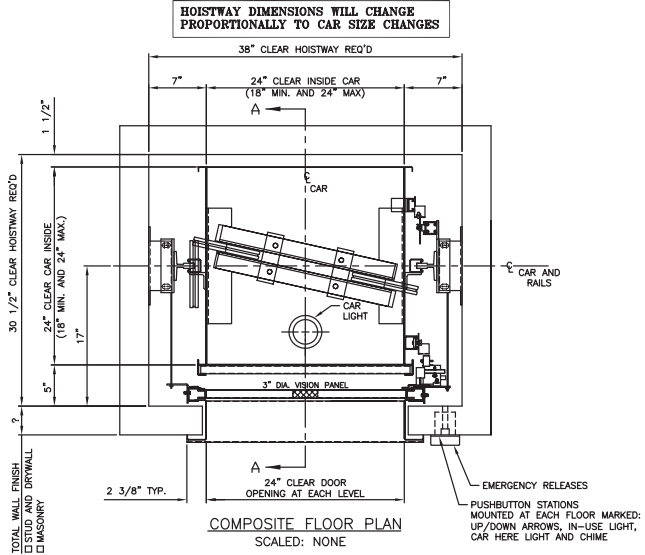

COMPOSITE FLOOR PLAN
SCALED: NONE

IMPORTANT:
BEFORE APPROVING THIS LAYOUT NOTE THAT THE FOLLOWING MUST BE PROVIDED BUT ARE NOT INCLUDED IN DUMB-WAITER CONTRACT:

- GENERAL NOTES**
- a. Power feed with line disconnect switch must be brought to immediate vicinity of our controller.
 - b. Hoistway free of all pipes and obstructions.
 - c. All bracket fastening inserts and steel required for support of guide rail and brackets, to be furnished by others.

WEIGHT OF MACHINE (EST.)	195 LBS.
WEIGHT OF CAR (EST.)	510 LBS. (GROSS)
REACTIONS	
A	1040 LBS. ESTIMATE (STATIC, AT SHAFT FLOOR)
B	790 LBS. ESTIMATE (STATIC, AT SHAFT FLOOR)
C	50 LBS. (LATERAL, MAX. AT WALL BRACKET)
OPENINGS	LOCATED SAME SIDE OF HOISTWAY
STOPS	2 MINIMUM TO 5 MAXIMUM, MORE STOPS CAN BE PROVIDED HOWEVER SPECIAL ENGINEERING IS REQUIRED CALL MATOT (800) 369-1070
MISC.: PREFIRED CAR TOP WITH ATTACHED TRAVEL CABLE	
SHELF	<input checked="" type="checkbox"/> REMOVABLE <input checked="" type="checkbox"/> 1-REQD.
CAR MATL.	<input checked="" type="checkbox"/> STAINLESS STEEL OR CARBON STEEL FINISH: NO. 4 OR AIR DRIED GREY ENAMEL
CABLE SIZE	<input checked="" type="checkbox"/> 3/16 x 7 x 19 1-REQD. <input checked="" type="checkbox"/> BREAKING STRENGTH 4200 LBS. EACH CABLE
CAR GATES 1-REQD.	<input checked="" type="checkbox"/> STAINLESS STEEL OR CARBON STEEL <input checked="" type="checkbox"/> BI-PARTING <input checked="" type="checkbox"/> MANUAL OR POWER (PLEASE SEE OVERHEAD REQUIREMENTS)
DOORS --REQD.	FINISH: NO. 4 OR AIR DRIED GREY ENAMEL <input checked="" type="checkbox"/> U/L B LABEL <input checked="" type="checkbox"/> STAINLESS STEEL OR CARBON STEEL <input checked="" type="checkbox"/> BI-PARTING <input checked="" type="checkbox"/> MANUAL OR POWER (PLEASE SEE OVERHEAD REQUIREMENTS)
SILLS	<input checked="" type="checkbox"/> COUNTER STAINLESS STEEL OR CARBON STEEL
ACCESS & CLEAN-OUT	<input checked="" type="checkbox"/> STAINLESS STEEL OR CARBON STEEL <input checked="" type="checkbox"/> U/L B LABEL
DOOR	FINISH: NO. 4 OR DRIED GREY ENAMEL <input checked="" type="checkbox"/> #6 TEE RAIL
HOISTWAY EQUIP.	
CAR SAFETY:	<input checked="" type="checkbox"/> BROKEN CABLE DEVICE
CONT. SAFETY:	NONE
BUFFERS:	NONE
MACHINE DESIGN	<input checked="" type="checkbox"/> DRUM BELOW <input checked="" type="checkbox"/> DRUM <input checked="" type="checkbox"/> REDUCER - 955MDT, 140TC FACE, 50:1 RATIO
H.P.	2 VOLTS 208-230 OR 460-480 PH. 3 CYL. 60 AMPS
OPERATION:	SINGLE AUTOMATIC CALL AND SEND <input checked="" type="checkbox"/> STARTING <input checked="" type="checkbox"/> RUNNING
CONTROL	<input checked="" type="checkbox"/> SINGLE SPEED <input checked="" type="checkbox"/> IN-USE LIGHT
SIGNALS	<input checked="" type="checkbox"/> CAR HERE LIGHT AND CHIME <input checked="" type="checkbox"/> DOOR OPEN BUZZER
CAPACITY:	200 LBS. F.P.M.50 TRAVEL:
TYPE DUMBWAITER:	ELEC. MODEL # 100
PROJECT:	
ARCHITECT:	
GENERAL CONTRACTOR:	
CONTRACT WITH:	
REVISIONS	DATE BY
MATOT, INC.	
SPECIALIZING IN DUMBWAITERS, BOOKLIFTS, RECORD CARRIERS, D. W. DOORS SINCE 1888	
2501 VAN BUREN, BELLWOOD, ILLINOIS 60104	
PHONE: AREA CODE (708) 547-1888	
PRELIM. PRINT	FINAL DRAWN BY CHECKED
JOB No.	SHEET 1 OF 1 DRAWING No.
INLINE COUNTER BP 24W X 24D X 38H	