

MATOT EQUIPMENT IS MANUFACTURED TO THE LATEST EDITION OF ANSI A17.1/CSA B44 CODE. IT IS THE RESPONSIBILITY OF THE PURCHASER TO CONFIRM COMPLIANCE WITH ANY LOCAL STATE OR CITY CODES.

TYPICAL

THESE DRAWINGS ARE TYPICAL AND REPRESENT STANDARD EQUIPMENT AND APPLICATIONS IF YOU HAVE A NEED BEYOND THE SCOPE OF THESE TYPICAL DRAWINGS MATOT CAN PROVIDE A SOLUTION. PLEASE CALL MATOT AT (800) 369-1070

****CAR MAXIMUM PLATFORM AREA (WIDTH X DEPTH) CANNOT EXCEED 1,548 IN. SQ. BY ANSI 17.1 CODE**

MINIMUM WALL THICKNESS REQUIRED FOR U.L. LABEL DOOR IS 3 1/2" MAXIMUM WALL THICKNESS IS 13 1/2"

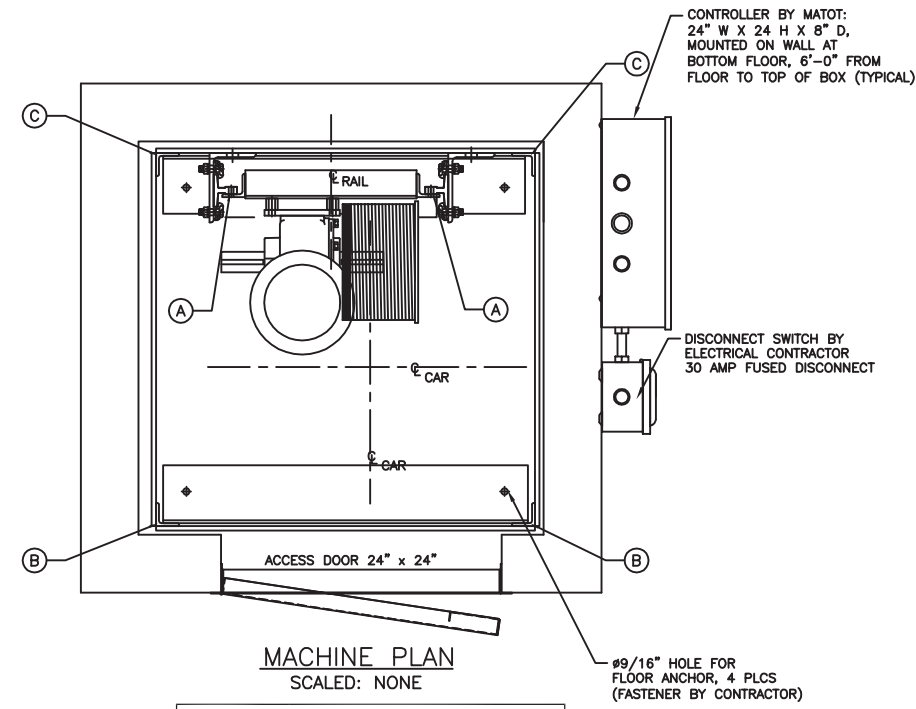

HOISTWAY DIMENSIONS WILL CHANGE PROPORTIONALLY TO CAR SIZE CHANGES

25" MAXIMUM TRAVEL FOR CARS UNDER 24"

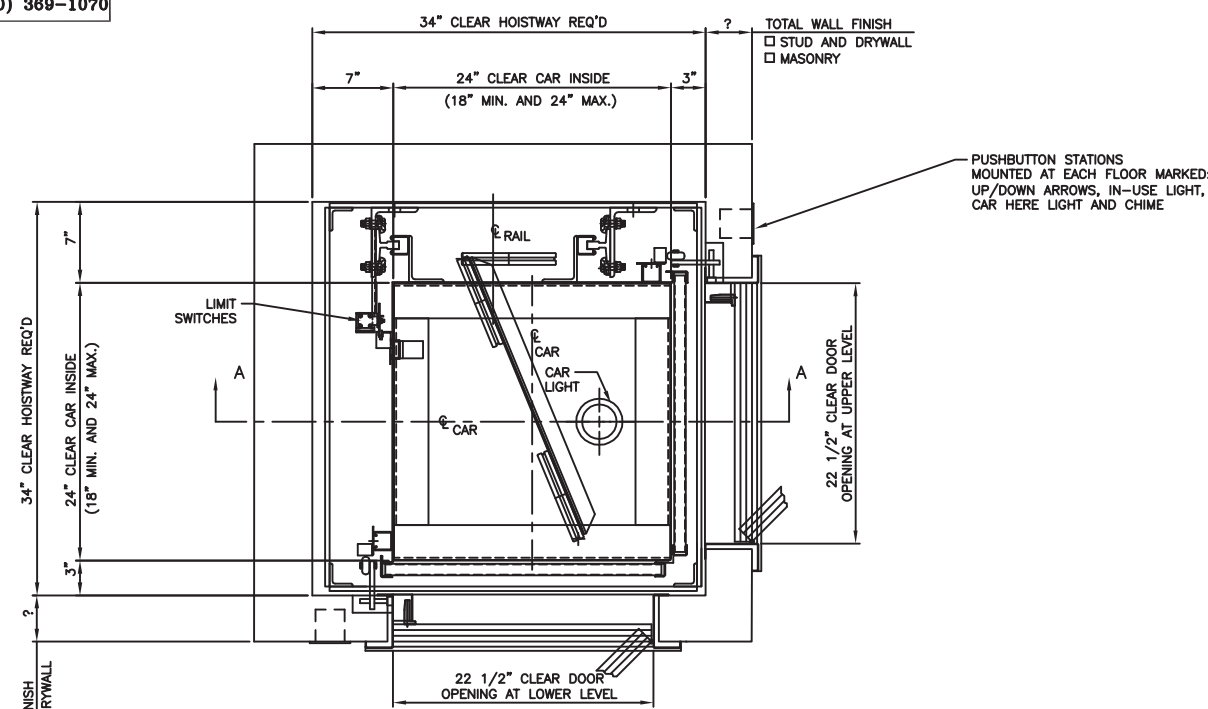

IMPORTANT:
BEFORE APPROVING THIS LAYOUT NOTE THAT THE FOLLOWING MUST BE PROVIDED BUT ARE NOT INCLUDED IN DUMBWAITER CONTRACT:

- GENERAL NOTES**
- Power feed with line disconnect switch must be brought to immediate vicinity of our controller.
 - Hoistway free of all pipes and obstructions.
 - All bracket fastening inserts and other steel required for support of guide rail and brackets, or tower to be furnished by others.
 - Self-supporting tower units to be installed before hatch walls are erected.
 - All truckable units require 2 inch deep pockets for trucking sills.

WEIGHT OF MACHINE (EST.)	195 LBS.
WEIGHT OF CAR (EST.)	610 LBS. (INCLUDES CAPACITY)
REACTIONS	
A 930 LBS (STATIC, AT SHAFT FLOOR)	D 100 LBS (LATERAL, MAX. AT WALL BRACKET)
B 720 LBS (STATIC, AT SHAFT FLOOR)	E
C 620 LBS (STATIC, AT SHAFT FLOOR)	F
OPENINGS:	LOCATED ADJACENT SIDES OF HOISTWAY
STOPS:	2 MINIMUM TO 5 MAXIMUM, MORE STOPS CAN BE PROVIDED
HOWEVER SPECIAL ENGINEERING IS REQUIRED CALL MATOT (800) 369-1070	
MISC.:	PREWIRED CAR TOP AND ATTACHED TRAVEL CABLE

SHELF	<input checked="" type="checkbox"/> REMOVABLE	1-REQD.
CAR MATL.	<input checked="" type="checkbox"/> STAINLESS STEEL OR CARBON STEEL	
	FINISH: NO. 4 OR AIR DRIED GREY ENAMEL	
CABLE SIZE	<input checked="" type="checkbox"/> 3/16 x 7 x 19	1-REQD.
	<input checked="" type="checkbox"/> BREAKING STRENGTH 4200 LBS	
CAR GATES 2-REQD.	<input checked="" type="checkbox"/> STAINLESS STEEL OR CARBON STEEL	
	<input checked="" type="checkbox"/> BI-PARTING	
	<input checked="" type="checkbox"/> MANUAL (PLEASE SEE OVERHEAD REQUIREMENTS)	
	FINISH: NO. 4 OR AIR DRIED GREY ENAMEL	
	<input checked="" type="checkbox"/> SWING HOISTWAY DOOR	
DOORS REQD.		
	FINISH:	
SILLS	<input checked="" type="checkbox"/> COUNTER HEIGHT	
ACCESS & CLEAN-OUT DOOR	<input checked="" type="checkbox"/> STAINLESS STEEL OR CARBON STEEL	
	<input checked="" type="checkbox"/> U/L B LABEL	
	FINISH: NO. 4 OR AIR DRIED GREY ENAMEL	
HOISTWAY EQUIP.	<input checked="" type="checkbox"/> TEE RAIL 6 #	
	<input checked="" type="checkbox"/> FULL TOWER	
CAR SAFETY:	NONE	
CWT. SAFETY:	NONE	
BUFFERS:	NONE	
MACHINE DESIGN	<input checked="" type="checkbox"/> DRUM BELOW (10" DIA.)	
	<input checked="" type="checkbox"/> DRUM	
	<input checked="" type="checkbox"/> REDUCER - 935MDT, 182TC FACE, 50:1	
H.P. 3	VOLTS 208-230 OR 460-480 PH. 3	CYL. 60
OPERATION:	SINGLE AUTOMATIC CALL AND SEND	AMPS STARTING RUNNING
CONTROL	<input checked="" type="checkbox"/> SINGLE SPEED	
	<input checked="" type="checkbox"/> DOOR OPEN BUZZER	
SIGNALS	<input checked="" type="checkbox"/> IN USE LIGHT	
	<input checked="" type="checkbox"/> CAR HERE LIGHT AND CHIME	

CAPACITY:	200 LBS.	F.P.M. 50	TRAVEL:
TYPE DUMBWAITER: ELEC. MODEL #110			
PROJECT:			
ARCHITECT:			
GENERAL CONTRACTOR:			
CONTRACT WITH:			
REVISIONS	DATE	DATE	DATE

MATOT, INC.

SPECIALIZING IN DUMBWAITERS, BOOKLIFTS, RECORD CARRIERS, D. W. DOORS SINCE 1888

2501 VAN BUREN, BELLWOOD, ILLINOIS 60104

PHONE: AREA CODE (708) 547-1888

PRELIM. PRINT	FINAL	DRAWN BY	CHECKED
JOB No.	SHEET 1 OF 1	DRAWING No.	ADJACENT COUNTER SWING 24" X 24" X 36"